



29810

# 1260 Series



Installation Instructions

## 1260 PULL SIDE (DOOR MOUNT) DROP PLATES

**PULL SIDE ARM MOUNTED ON:  
1260-18 DROP PLATE**

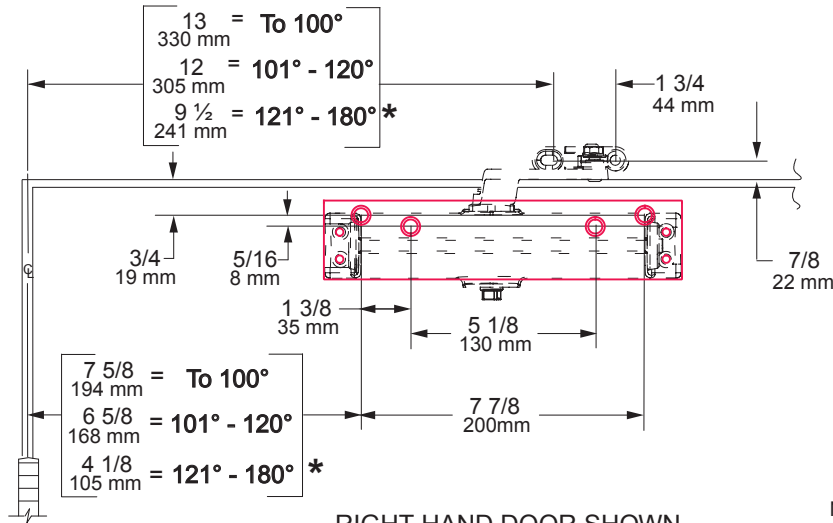

RIGHT HAND DOOR SHOWN  
LEFT HAND DOOR OPPOSITE

NOTES -  
1. MINIMUM TOP RAIL HEIGHT IS 1 1/2".  
\* 2. TRIM PERMITTING.

## 1260 PUSH SIDE (TOP JAMB) DROP PLATES

**PUSH SIDE ARM MOUNTED ON:  
1260-18 DROP PLATE**

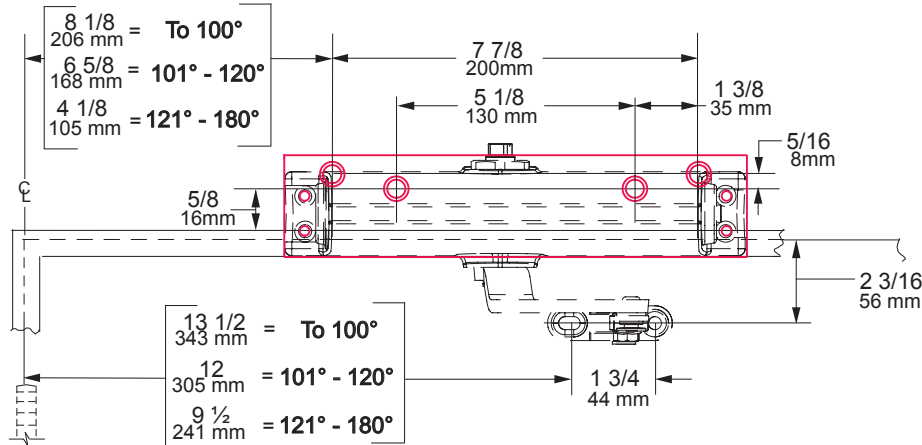

LEFT HAND DOOR SHOWN  
RIGHT HAND DOOR OPPOSITE

NOTES -  
1. MINIMUM FACE FRAME IS 1 3/8".

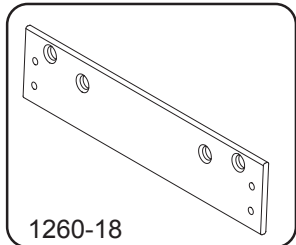

1260-18

### GENERAL NOTES:

1. ON TOP JAMB & HINGE FACE MOUNTS. LOCATE CLOSER & SHOE FROM CENTERLINE OF PIVOT OR SWING CLEAR HINGE PIN WHEN USED.
2. ON TOP JAMB MOUNTING WHEN OVERHEAD STOP IS USED, SHOE MUST BE LOWERED TO CLEAR HOLDER.
3. FOR 180° OPENING, MAX BUTT SIZE IS 5" X 5"
4. REINFORCING PER ANSI/SDI-100 RECOMMENDED FOR HOLLOW METAL DOORS AND FRAMES.
5. CLOSER SIZE IS 10" x 2 1/4" x 2 7/8".

**P1260 PUSH SIDE (DOOR MOUNT) DROP PLATES**

**PUSH SIDE PARALLEL ARM MOUNTED ON:  
1260-18PA DROP PLATE**

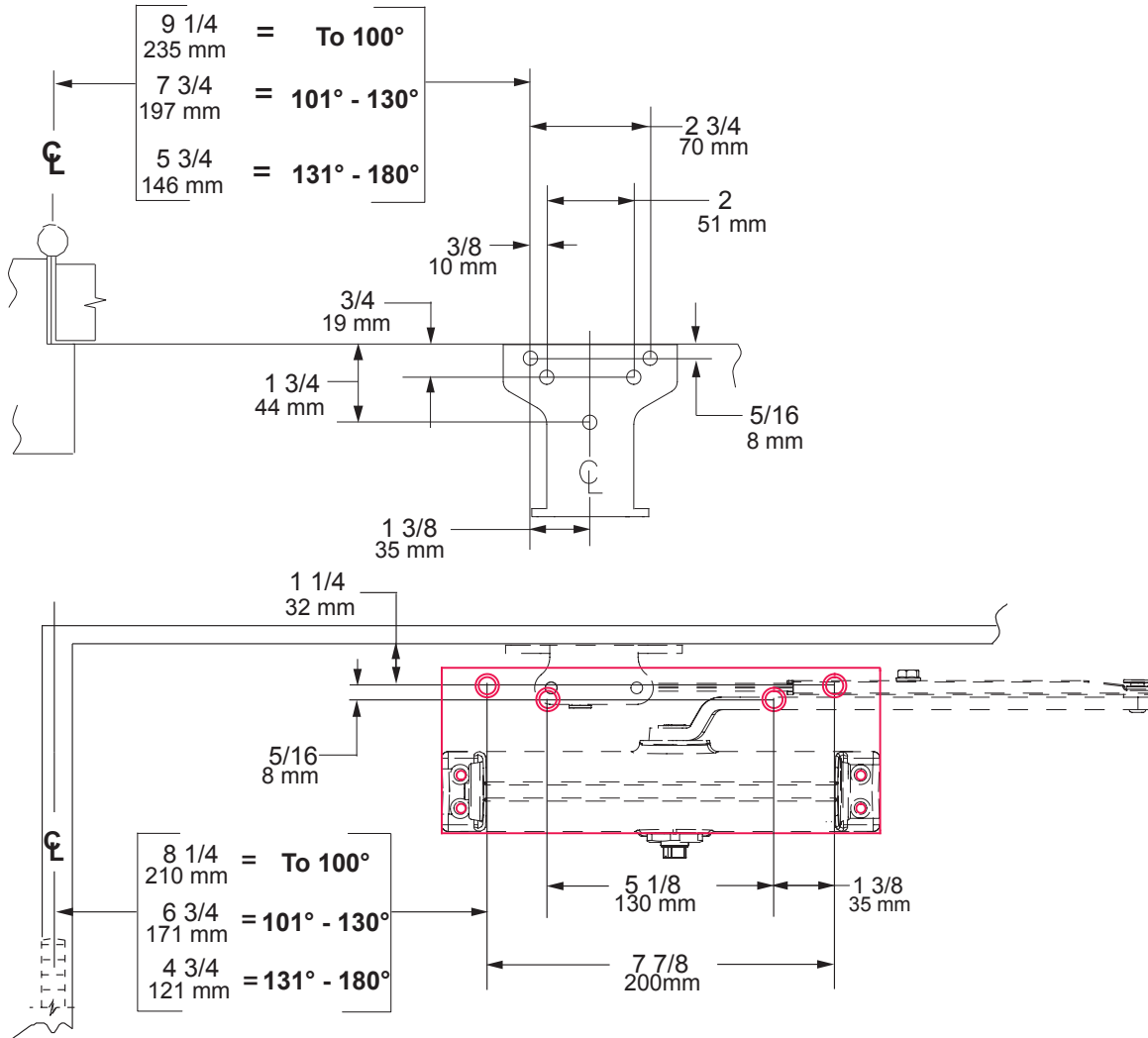

LEFT HAND DOOR SHOWN  
RIGHT HAND DOOR OPPOSITE

NOTES -  
1. MINIMUM TOP RAIL 2 1/2".

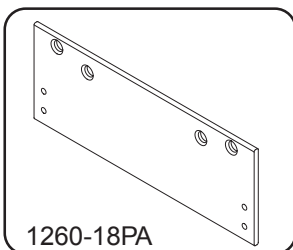

**GENERAL NOTES:**

1. LOCATE CLOSER & SHOE FROM CENTERLINE OF PIVOT OR SWING CLEAR HINGE PIN WHEN USED.
2. FOR 180° OPENING ON HINGE FACE MOUNTS, MAX BUTT SIZE IS 5" X 5"
- 3 REINFORCING PER ANSI/SDI-100 RECOMMENDED FOR HOLLOW METAL DOORS AND FRAMES.
4. CLOSER SIZE IS 10" x 2 1/4" x 2 7/8".

**1260 EDA  
DROP PLATES**

**PUSH SIDE, PARALLEL ARM MOUNTED ON:  
1260-18PA DROP PLATE**

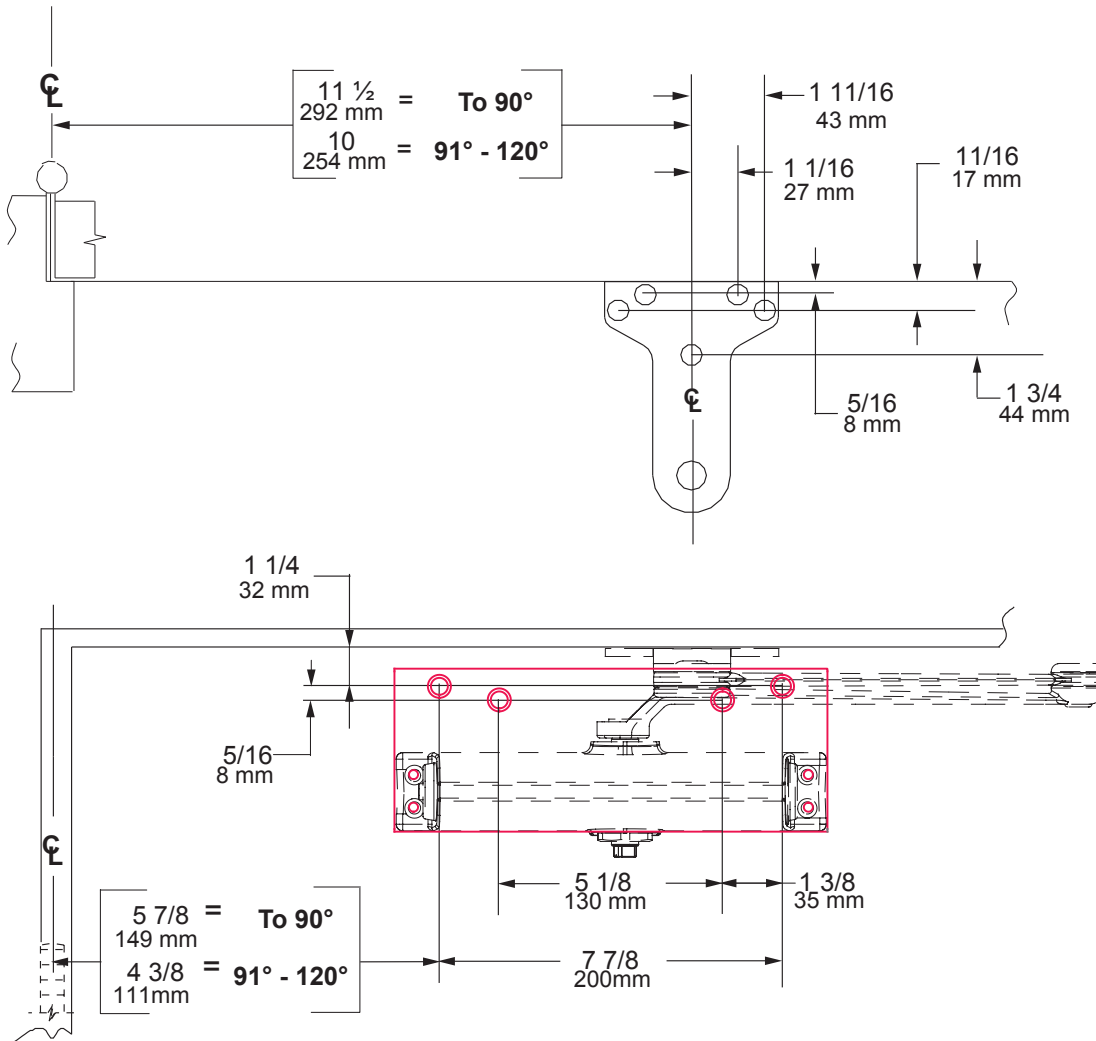

LEFT HAND DOOR SHOWN  
RIGHT HAND DOOR OPPOSITE

NOTES -  
1. MINIMUM TOP RAIL 2 1/2".

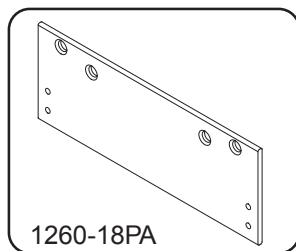

1260-18PA

**GENERAL NOTES:**

1. IF DOOR IS HUNG ON PIVOTS OR SWING CLEAR HINGES LOCATE CLOSER AND SHOE FROM CENTER LINE OF PIVOT POINT.
2. CLOSER SIZE 10" x 2 1/4" x 2 7/8".
3. TOP RAIL LESS THAN 4 3/4" REQUIRES DROP PLATE.
4. ALL DIMENSIONS APPLICABLE FOR HOLD OPEN.
5. DELAYED ACTION OPTIONAL.
6. REINFORCING PER. ANSI/SDI-100 RECOMMENDED FOR HOLLOW METAL DOOR AND FRAMES.
7. USING FASTENERS PROVIDED MOUNT DROP PLATE WITH (4) 1-3/8" SRT, 1-1/2" WOOD, 5/8" MACHINE OR 5/8" TORX MOUNTING SCREWS. MOUNT CLOSER CYLINDER TO DROP PLATE USING (4) 1/4-20 X 1/2" SCREWS. MAX. BUTT HINGE SIZE 5 X 5.

**1260 CUSH  
DROP PLATES**

**PUSH SIDE, PARALLEL ARM MOUNTED ON:  
1260-18PA DROP PLATE**

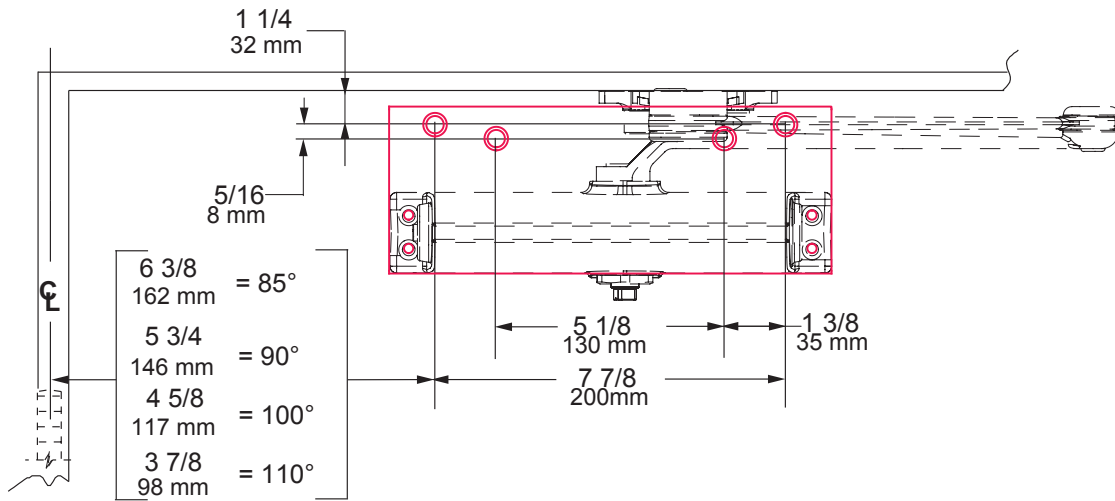
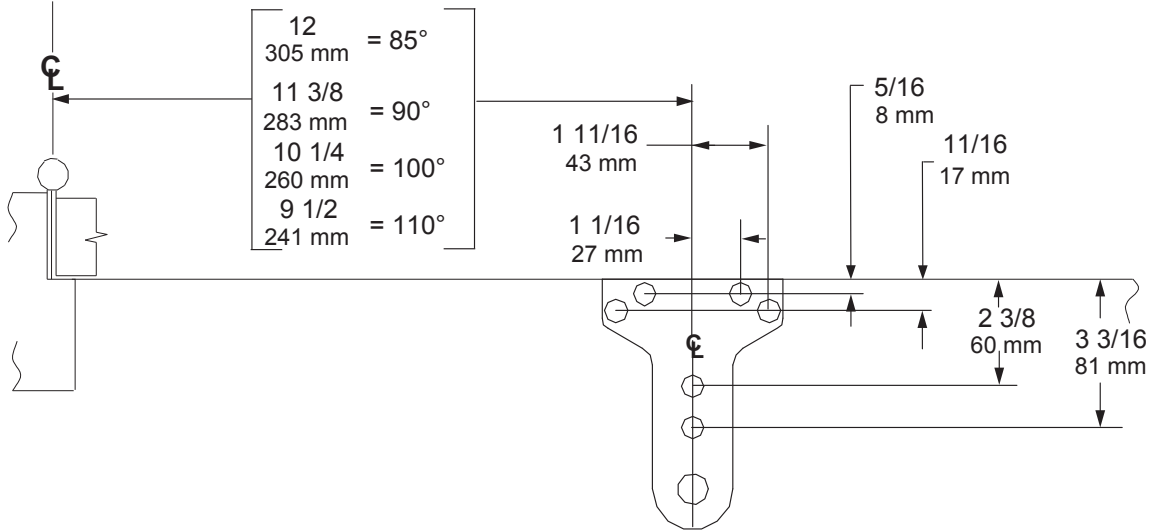

LEFT HAND DOOR SHOWN  
RIGHT HAND DOOR OPPOSITE

NOTES -  
1. MINIMUM TOP RAIL 2 1/2".

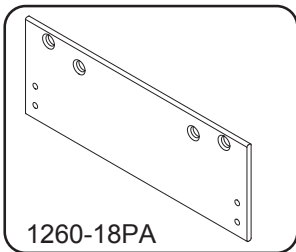

1260-18PA

**GENERAL NOTES:**

1. IF DOOR IS HUNG ON PIVOTS OR SWING CLEAR HINGES LOCATE CLOSER AND SHOE FROM CENTER LINE OF PIVOT POINT.
2. CLOSER SIZE. 10"x 2 1/4"x 2 7/8"
3. TOP RAIL LESS THAN 4 3/4 REQUIRES DROP PLATE.
4. ALL DIMENSIONS APPLICABLE FOR HOLD OPEN OR DEAD STOP.
5. DELAYED ACTION OPTIONAL.
6. REINFORCING PER. ANSI/SDI-100 RECOMMENDED FOR HOLLOW METAL DOOR AND FRAMES.

**Customer Service**

1-877-671-7011 [www.allegion.com/us](http://www.allegion.com/us)



© Allegion 2014  
Printed in U.S.A.  
29810 Rev. 12/14-c